

Bachelor Thesis Idea

Title: Batteryless Spectrometer for Smart Lighting Applications

The rapid growth of the Internet of Things (IoT) is transforming conventional buildings into intelligent and energy-efficient environments. Among the key components of smart buildings, lighting systems play a central role in reducing energy consumption while improving user comfort. Modern smart lighting solutions increasingly rely on sensing technologies to enable adaptive and autonomous operation. Beyond simple intensity control, spectral information of light is becoming highly relevant for applications such as human-centric lighting, color quality optimization, and advanced energy management. Despite its importance, spectral sensing remains largely absent in distributed smart lighting systems.

Conventional spectrometers are typically expensive, bulky, and power-hungry, making them unsuitable for large-scale deployment in IoT environments. Battery-powered sensing nodes further introduce maintenance challenges and limit scalability due to periodic battery replacement. For future smart lighting infrastructures, sensing devices must be low-cost, ultra-low-power, and ideally maintenance-free. Currently, there is a lack of compact and batteryless spectrometer solutions that can be seamlessly integrated into closed-loop indoor lighting control systems. Enabling spectral feedback in a fully energy-autonomous device presents significant challenges in terms of hardware design, power management, and system integration. This thesis aims to address these challenges by designing and prototyping a batteryless spectrometer and demonstrating its feasibility within a real indoor smart lighting environment.

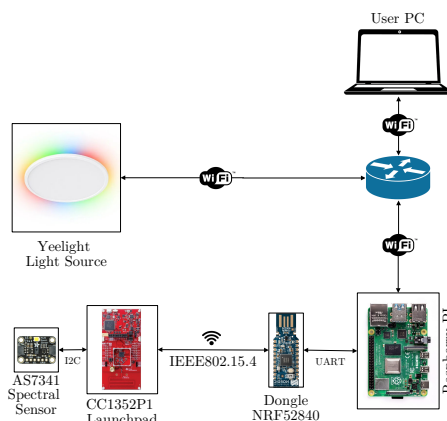

Goals:

- Design and development of a low-cost, ultra-low-power spectrometer suitable for IoT-based smart lighting applications.
- Implementation of a batteryless prototype, including energy management and embedded system design.
- Integration and experimental validation of the device within a closed-loop indoor smart lighting system.

Contact:

- Juan Felipe Gutiérrez Gómez (juan-felipe.gutierrez-gomez@tu-braunschweig.de)