

SFB 880 - FUNDAMENTALS OF HIGH-LIFT FOR FUTURE COMMERCIAL AIRCRAFT

R. Radespiel, TU Braunschweig, Institute of Fluid Mechanics, Hermann Blenk Str. 37,
38108 Braunschweig, Germany

W. Heinze, TU Braunschweig, Institute of Aircraft Design and Lightweight Structures,
Hermann Blenk Str. 35, 38108 Braunschweig, Germany

Abstract

The recently founded Collaborative Research Centre SFB 880 of the Technische Universität Braunschweig, „Fundamentals of High-Lift for Future Commercial Aircraft“, develops new knowledge in aircraft noise, in advanced approaches towards active high lift, and in the dynamics of flight with active high lift during short take-off and landing operations. The Research Centre has therefore devised a range of research projects that aim at integrated aeroacoustic and aerodynamic design capabilities for drastic noise reductions and at the generation of active high lift with an extremely high efficiency of the used onboard power. Flight dynamics of commercial aircraft with increased lift capabilities for take-off and landing due to means of active control and including the effects of aeroelasticity and engine failure modes are also investigated. The Research Centre has developed a joint strategy for technology assessment using high-quality conceptual design data of a reference aircraft that represents the state of the art in CO₂ reductions, low noise, and short take-off and landing for point-to-point air connections within Europe. The paper describes the overall strategy of the coordinated research work and gives examples of recent results.

1. INTRODUCTION

The mobility needs of industrialized countries have resulted in continuous growth rates of air transportation that bring our aviation system close to its capacity limits and add significantly to CO₂ emissions, perceived noise and land usage. These issues are strongly reflected in the recently published “Vision Flightpath 2050 - Strategic Research and Innovation Agenda” [1]. According to these long-term industrial objectives of the major European aviation stakeholders, new technological approaches can only be successful if they address simultaneously environment protection, drastic energy savings, improved flight safety, and reductions in door-to-door travel times as the enabler for continuous growth in European aircraft manufacture and aviation operations.

A more detailed view on technologies for future commercial transport reveals the large role that the high-lift system of the aircraft has on the aircraft operating cost, on the usage of natural resources and on aircraft emissions, as well as on flight safety. The multi-element high-lift systems used on current aircraft have a multitude of effects on aircraft performance. While their manufacture and maintenance directly affect aircraft operation cost, the lift generation capabilities of these systems allow overall wing design for optimum cruise efficiency and enable aircraft service to a prescribed class of airport infrastructures. However, the current high-lift systems exhibit very limited flexibility to extend their performance once wing sizing and the integration of the leading edge and trailing edge devices for high-lift have taken place. This leaves very little room to adapt take-off and landing performance to a growing aircraft weight or to configuration changes such as the installation of an engine with a larger diameter, during the lifespan of an existing aircraft family. Fur-

ther, the need for conventional leading edge devices is a severe difficulty in the introduction of laminar flow on the wing, as envisaged for significant cruise drag reductions. Finally, conventional slats and high-lift flaps represent a major source of airframe noise on current aircraft. Note that the performance of the high-lift system directly affects the air speed at take-off and approach conditions and hence all sources of airframe noise, as these sources scale with the 5th to 6th power of flow speed.

The recently founded Collaborative Research Centre SFB 880 located in Braunschweig, Germany, combines the competencies of Technische Universität Braunschweig, Universität Hannover and the German Aerospace Center, DLR, for fundamental and applied research in high-lift of future commercial aircraft. The overall working hypothesis of the Research Centre SFB 880 states that active high-lift systems with high levels of aerodynamic efficiency will add significant value to future civil transport. These active systems will provide much higher flexibility in the generation of high-lift for aircraft families and aircraft upgrades, they will allow significant reductions of airframe noise emissions, and they provide a viable path towards Short Take Off and Landing (STOL) capabilities. The latter route of research aims at a new transport aircraft segment for operation on airports with shorter runway length presently not considered in commercial air transport [2]. The new class of aircraft would be equipped with advanced technologies for drastic airframe and engine noise reduction. It would represent a community friendly aircraft (labelled “Bürgernahe Flugzeug” in German language) designed for operations much closer to the home of its passengers than possible today.

The Research Centre SFB 880 has therefore devised a range of technology projects that aim at drastic noise reductions and at the generation of efficient and flexible

high-lift. The research also addresses flight dynamics of aircraft at take-off and landing.

Research Area A “Fundamentals of Aeroacoustics” develops an integrated aero-acoustic and aerodynamic design methodology. The Research Area aims at reductions of airframe noise sources and the use of aircraft surfaces capable of reducing the generation of aerodynamic noise combined with new configuration approaches. Newly developed computational capabilities will be applied to explore the reduction of airframe noise sources by surface materials with tailored porosities. Similar significant reductions of the aircraft noise related to propulsion appear possible by using close integration of the propulsor with the wing. This calls for understanding the physics related to propulsive efficiency, propeller noise generation and shielding. Close integration of propeller and wing flow lead to the risk of increased acoustically induced structural vibrations and corresponding larger cabin noise levels. Modeling the related transmission paths is therefore addressed by the research as well.

Flexibility in the performance of high-lift systems beyond the current multi-element mechanical solutions can be only obtained by employing the high flow turning offered by active flow control. A powerful control means is obtained by tangential blowing over carefully designed flow turning surfaces, hence making use of the Coanda-effect. Research Area B “Efficient High Lift” focuses on active high-lift flaps with Coanda-type blowing with the aim to obtain drastic reductions of the needed blowing power. The Research Area brings together design advances in aerodynamics, new flow sensors and flow actuators, new adaptive wing structures and advanced compressor technology.

Research Area C “Flight Dynamics” aims at extending the rather limited knowledge base on the flight dynamics of commercial aircraft that use means of active control for increased lift capability at low-speed flight. Flow simulation of aircraft configurations are used to characterize transient behaviors of flow control and to provide an aerodynamic data base. The data base is used in flight simulations which also take the wing aero-elastic degrees of freedom into account. These flight simulations identify suited control approaches and they provide control requirements to cope with atmospheric disturbances and engine failure modes.

Technology assessment plays an integrated part in coordinating the Research Centre SFB 880. For this purpose a reference aircraft configuration is developed as a fully iterated preliminary aircraft design. The reference configuration represents the state of the art in CO₂ reductions, low noise, and STOL for point-to-point air connections within Europe. The design is used to assess the individual impact that the various research projects on aeroacoustics, aerodynamics, advanced wing materials and structures, and aircraft flight mechanics have. As the research work in the three Research Areas, A, B, C, need a reference aircraft configuration for guiding method development, simulations and analysis, the operation scenario and aircraft design are presented in the following chapter.

2. REFERENCE CONFIGURATION AND TECHNOLOGY ASSESSMENT

The Collaborative Research Centre SFB 880 investigates a broad range of aircraft technologies where the importance and benefits of the individual approaches can only be assessed by taking the complex interactions in transport aircraft design into account. The Research Centre therefore operates a central project on preliminary aircraft design with the objective to identify and quantify those interactions. The aircraft design project has the task to supply aircraft requirements and design data to the cooperating research projects, which enables them to perform useful and consistent simulations, experiments and analysis of the results. The design project, on the other hand, uses technology data obtained from the various research projects, such as geometrical descriptions, aerodynamic and weight data etc. in order to compute the technology impact on STOL performance, fuel burn, noise impact, direct operating cost (DOC), and other relevant quantities. For this purpose a well established preliminary aircraft design simulation method is employed and refined as necessary.

As part of the research strategy of the SFB 880 at least two virtual aircraft configurations are needed to assess the technological progress of the Centre:

- The long-term vision of a new segment of cruise-efficient low-noise transport aircraft with STOL capabilities is projected into the **SFB 880 Reference Configuration**. The Reference Configuration for around 100 passengers with a range of 2000km features advanced turboprop propulsion along with internally blown high-lift flaps (IBF), as displayed in FIGURE 1.

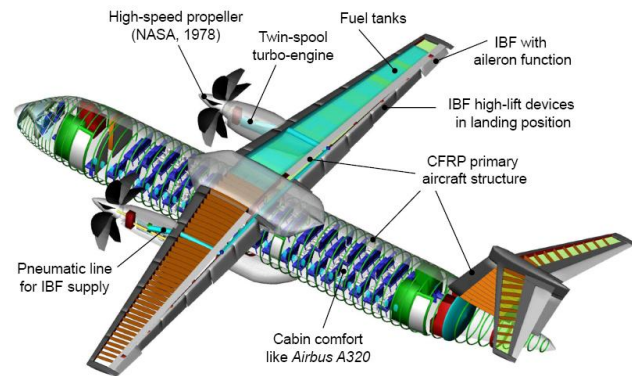

FIGURE 1. SFB 880 Reference Configuration

The design employs present state-of-the-art technologies available for operation in the year 2025. The present concept of the Reference Configuration is viewed as a technologically sound starting point for fundamental research work.

- Broad mid-term application areas of the collaborative research are addressed by defining a suited **SFB 880 Transfer Configuration**. The Transfer Configuration is used to assess technology values in conventional transport aircraft. This configuration is modeled as a modern fan engine aircraft of the Airbus 320 class.

2.1. Preliminary Aircraft Design Method

For overall design analysis and optimization of transport aircraft configurations, the Preliminary Aircraft Design and Optimization tool PrADO [3] of Technische Universität Braunschweig is used. PrADO has a modular structure and simulates the iterative overall design process for any desired aircraft concept, according to FIGURE 2. The core consists of a set of the design modules (MD), each of which fulfills a subtask in the design sequence. In order to provide a wide range of applications, the modules largely use physics-based models that are not bounded by statistics or specific aircraft configurations. These modules communicate with each other through a data management system, which offers flexibility to adapt PrADO to new design problems. The design core is enclosed by additional loops which allow an automatic variation or optimization of design variables describing the aircraft configuration and the propulsion system.

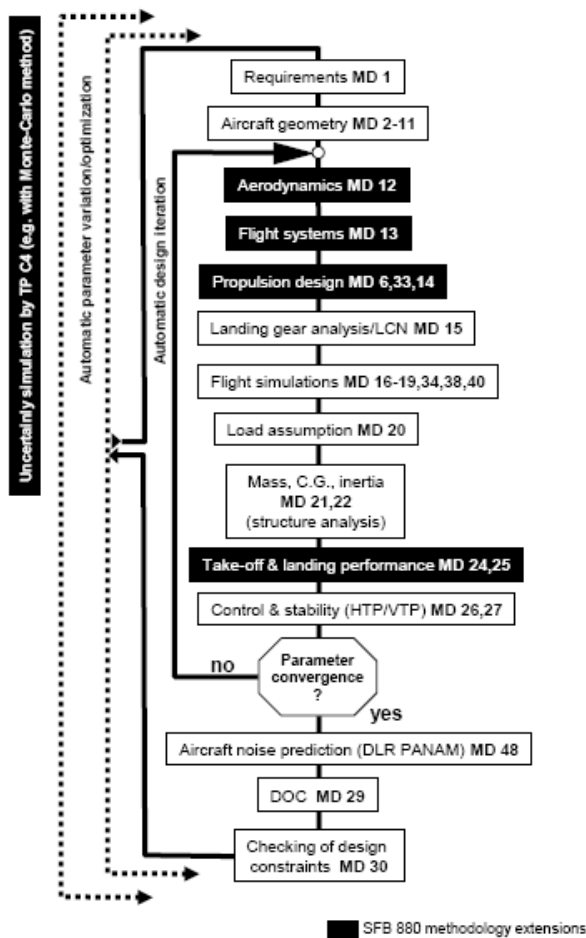

FIGURE 2. Schematic of Preliminary Aircraft Design with PrADO with design modules (MD)

The analysis of an aircraft with active high-lift system requires several methodology extensions. To calculate the aerodynamic characteristics of the STOL aircraft, a multiple lifting line method with modeling of IBF using 2D RANS airfoil data is used [4]. During the present, initial stage of the project, propeller slipstream effects are neglected for the calculation of the aerodynamic characteristics. The system aspects of the active flaps are included in

PrADO by an aircraft system model from Koeppen [5] which has been supplemented by a pneumatic line for compressed air supply [4]. The systems design module calculates the masses and center of gravity positions of the pipes, valves, and distribution elements including the necessary flow properties (flow mass rate, temperature and total pressure) at the engine bleed port. These data are used for engine sizing and for the calculation of the engine off-design behavior with or without operation of the internally blown flap system. For engine design and analysis, a thermodynamic engine model based on Mattingly [6] is available. Further necessary data for engine design, including the propeller size and mass, gear box mass, and propeller efficiency factor, are taken from detailed NASA studies [7]. Note that the documented propeller of Ref. [7] has its highest efficiency factors in the Mach regime between 0.7 and 0.8 and is well suited for a 100-seater.

2.2. SFB 880 Reference Configuration

The SFB 880 Reference Configuration shown in FIGURE 1 has a high wing arrangement with turboprop engines mounted in front of the wing. The efficient propulsion system in combination with a carbon fiber reinforced plastics (CFRP) primary structure leads to a reduced takeoff and landing weight which helps to achieve the given STOL requirements. The pivotal element is however the IBF system that enables large flow turning and hence 50% larger lift coefficients compared to conventional multi-element solutions. The extraction of compressed air takes place behind the low pressure compressor (LPC) of the engine to allow for a safe IBF operation in all low-speed flight phases. The necessary LPC pressure ratio is 2.7 including one-engine-inoperative (OEI) conditions.

	Conventional Aircraft	SFB 880 Reference Configuration
Max payload	12000kg/100PAX	12000kg/100PAX
Range	2000km	2000kg
High lift system	Slat and Fowler	IBF
Propulsion	Fan engine	Turboprop engine
MTOW	42664kg	41922kg
Cruise Mach no.	0.78	0.74
Wing loading	533 kg/m ²	456 kg/m ²
Thrust/weight	0.41	0.53
L/D (cruise)	14.63	14.55
T/O field length	1456m	800m
Landing field	1803m	782m
SFC at cruise	0.0642 kg/(N h)	0.0478 kg/(N h)
DOC	0.081 \$/seat km	0.076 \$/seat km

TAB 1. Selected design data of SFB 880 Reference Configuration

The IBF system is designed for maximum aircraft lift coefficients of 3.5 during take-off and approach and for values of 4.5 during the final phase of the landing. That determines the necessary mass flow rates of 14.4 kg/s during take-off with moderate flap angles of 43° and of 17.2 kg/s during the landing with flap angles of around 65°. Each of

the two engines is designed to deliver the full IBF flow rates for the whole high-lift system as necessary in an OEI situation.

The wing has a simple tapered planform with a low leading edge sweep of 10° to reduce wing weight and manufacturing cost. In addition the reduced sweep improves the usable maximum lift coefficient, which is approx. 11% higher compared to a wing with 28° sweep. The empennage is arranged as a classical T-tail to move the horizontal stabilizer out of the propeller slipstream.

Top-level aircraft design requirements are shown in TAB 1. The optimal cruise condition for the Reference Configuration is found at Mach 0.74 and 10.6 km altitude with the parameter variation mode of PrADO, as displayed in FIGURE 3. The objective is here to minimize DOC without exceeding the cruise lift coefficient of 0.5. The optimal Mach number depends on the propeller characteristics while the cruise altitude results from the constraint on lift coefficient at this operating point.

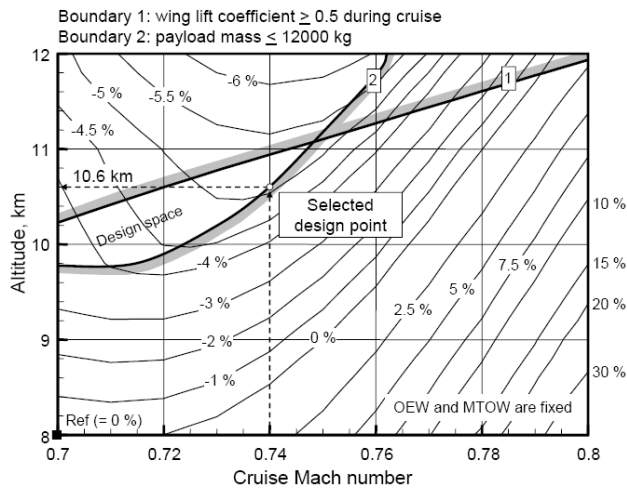

FIGURE 3. Effect of Mach number and Altitude on DOC

The wing loading and planform of the SFB 880 Reference Configuration were also optimized. Starting point was a wing layout based on the Fairchild-Dornier 728/928 project. This aircraft was redesigned with PrADO assuming a CFRP primary structure and a 100-seat 2000km mission with conventional high-lift devices (slat and Fowler flap). This design is denoted as conventional aircraft in the following.

FIGURE 4 shows the wing loading as a function of the thrust-to-weight ratio for the SFB 880 design requirements. As the landing distance requirement of 800 m determines the wing area, the IBF approach shows its clear advantage. With active high lift a wing loading of about 456 kg/m^2 is achieved which makes the STOL aircraft competitive to conventional aircraft in cruise. The corresponding lift-to-drag ratio is almost identical to the conventional aircraft, see TABLE 1. On the other hand, the aircraft thrust is driven by the take-off requirement of 800m FAR 25 runway length. The STOL aircraft needs approx. 28% more maximum take-off thrust which includes the power for the air extraction from the engine.

The optimization of other wing planform parameters, as seen in FIGURE 5 for wing aspect ratio and wing taper, is dominated by their effects on the wing structural loads leading to a lighter wing and therefore a cheaper aircraft. Note that due to the rather low range of the selected aircraft class and despite of assuming a 50% higher than present oil price for the year 2025, the fuel costs make only 23% of the direct operating costs.

- A: Takeoff distance $\leq 800 \text{ m}$ (= BFL, FAR 25)
- B: Landing distance $\leq 800 \text{ m}$ (FAR 25)
- C: Cruise at 10.6 km with $Ma = 0.74$
- D: Steady flight at 5.4 km with $Ma = 0.5$, one engine out
- E: Minimum climb angle at takeoff, one engine out (FAR 25, 2nd segment, IBF system on)
- F: Minimum climb angle at approach, one engine out (FAR 25, IBF system on)

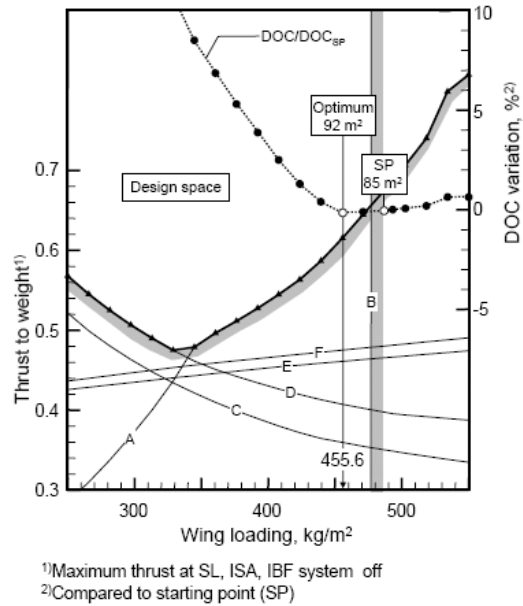

FIGURE 4. Variation of thrust-to-weight ratio and DOC over wing loading.

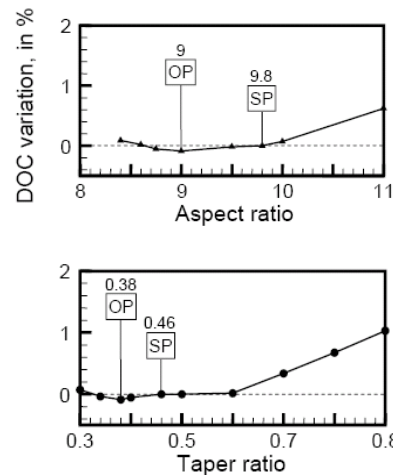

FIGURE 5. Optimization of wing planform parameters (SP - starting point, OP - selection for SFB 880 Reference Configuration)

Finally, TAB 1 compares important aircraft performance parameters of the SFB 880 Reference Configuration to

the conventional aircraft with fan engines and passive high-lift devices. In spite of a 15% higher wing area and 28% more (installed) static thrust, the Reference Configuration with IBF system shows about 6% less direct operating costs while the take-off and landing distances are about 50% smaller. This is due to the combined effects of active flow control and turboprop engine characteristics.

2.3. Design Uncertainty Assessment

The overall objective of the Reference Configuration is to function as a virtual application reference based on sound design and technology data. Further, any incremental design result for the Reference Configuration should represent the progress in technology achieved by SFB 880 research work in a smooth and reliable way. This calls for a robust aircraft configuration.

The design of the SFB 880 Reference Configuration is based on design data with significant uncertainty, though. The assumed maximum lift coefficient of overall aircraft with the active high lift system, for example, depends on the uncertainty with respect to the flow simulation method and this affects landing field length, while the assumed CFRP material data come with an uncertainty that affects aircraft empty weight.

As the Reference Configuration represents an aircraft that is quite different from commercial aircraft in present service there is no statistical data that could be used for a conclusive verification of the computed design. This situation motivates an analysis of the effects of data uncertainties on the design of this novel aircraft configuration. The uncertainty analysis is performed to identify design parameters where the associated uncertainties have large effects on aircraft size, performance and cost and to identify the critical growth of aircraft components.

The uncertainty analysis of the SFB 880 Reference Configuration is here based on Monte-Carlo simulations with the design method PrADO. For this purpose uncertainty bands were defined for a selected number of design input data as shown in TAB 2. The sizes of these uncertainty bands were estimated based on expert knowledge. The stochastic values within these bands were always equally distributed. This procedure resulted in totally 12191 full design runs of PrADO.

FIGURE 6. Effects of fuselage mass, lift and blowing mass flux errors on landing field length

Uncertain Parameter	Uncertainty band
Aerodynamics	
lift coefficient	-5%....+5%
induced drag	-5%....+5%
zero lift drag	-5%....+5%
Structure	
wing mass	-5%....+5%
fuselage mass	-5%....+5%
Propulsion	
compressor efficiency	-3%....+3%
high pressure turbine eff.	-3%....+3%
Low pressure turbine eff.	-3%....+3%
fuel burn factor	-3%....+0%
total pressure ratio	-3%....+3%
Maximum turbine entry temp.	-3%....+3%
engine mass	-5%....+5%
Internal blowing system	
mass	-50%....+100%
needed mass flux	-5%....+5%

TAB 2. Selected uncertainty bands for Monte-Carlo design simulation

Each of these individual design runs required several hours of computing time on a state-of-the-art processor. Therefore the computations were parallelized on 24 processors. The Monte-Carlo simulations were then evaluated to yield probability distributions on the resulting design. The effects of parameter uncertainties on the design are evaluated by monitoring technical aircraft parameters, i.e. engine shaft power, aircraft empty weight, cruise L/D, fuel mass, FAR25 landing field length, DOC, while the take-off field length of 800m was kept constant as a constraint. The individual designs represent the sensitivities of the design to the uncertainties of design parameters as displayed in FIGURE 6, for the example of the landing field length. It turns out that the landing field length depends somewhat on the fuselage mass but very little on changes of the required IBF mass flux. There is a clear effect of the lift coefficient on field length, as expected,

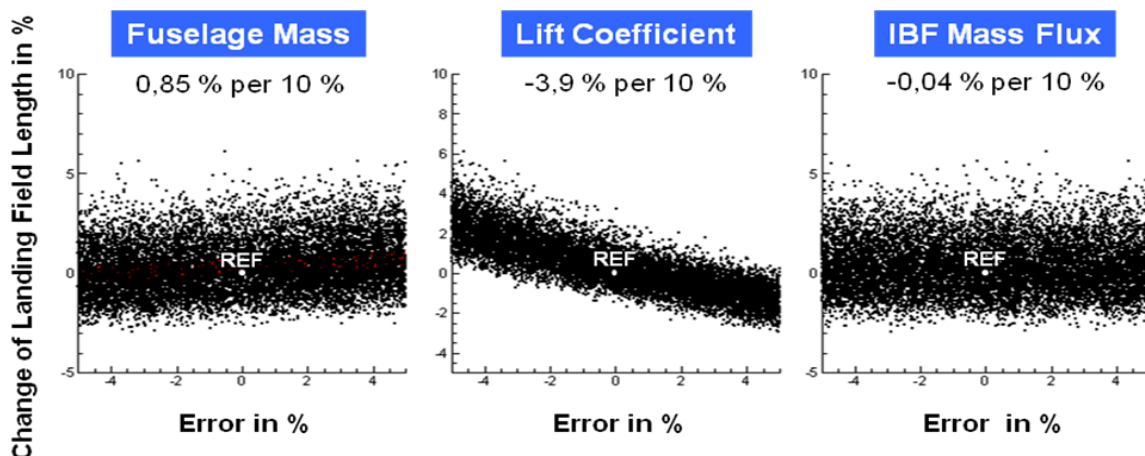

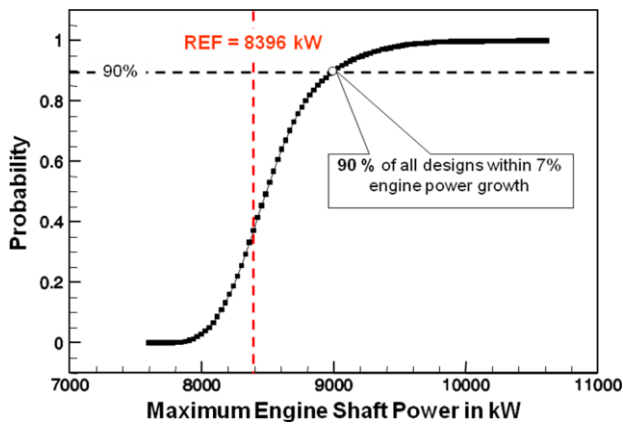

FIGURE 7. Engine growth over all design samples

but the sensitivity is moderate. In general the SFB 880 Reference Configuration appears as a robust aircraft design. Adverse variations of lift, weight and propulsive efficiency result in engine growth needed to fulfill the 800m take-off field constraint. This growth, however, is moderate as seen in FIGURE 7. The uncertainty analysis shows that 90% of all parameter variations can be covered with an increase of engine shaft power by 7%. Note that the maximum increase of DOC for these samples was only 2.5%. The present results indicate that the design objectives of the SFB 880 Reference Configurations are met.

3. SFB 880 RESEARCH AREAS

The collaborative research of the SFB 880 aims at drastic reductions of aircraft noise, at a new level of flexibility in the achievable lift coefficient for high lift systems, and at a fundamental knowledge base on the dynamics of commercial aircraft with STOL capabilities. These basic research directions are strongly interrelated. For example, the aircraft flow noise depends largely on configuration and performance of the high-lift system, whereas the aerodynamic approach to achieve high lift coefficients has to comply with certain constraints set by flight mechanical analysis of the overall aircraft. The logic of the three Research Areas of the Research Centre SFB 880 and their current status will be briefly described in the following. The reader is referred to Refs. [8],[9],[10] for more details on the individual research areas.

3.1. Fundamentals of Aeroacoustics

Active high-lift systems are employed to enable much improved short take-off and landing capabilities for future commercial aircraft, while reductions of airframe noise due to reduced flight speed appear generally possible. However, the new high-lift approaches also bear the risk of new noise sources. These are noise from the interaction of locally high-speed turbulent flows with configuration edges and noise from the interaction of the propulsor with the airframe. The research approach of the Research Centre for drastic noise reductions employs therefore the combination of using the potentials of noise source reducing and noise absorbing aircraft surfaces and also configurational measures to exploit the acoustic synergies offered by integration of propulsion and airframe.

The schematic of fundamental research in aeroacoustics is displayed in FIGURE 8. The use of tailored materials for airframe noise reduction needs an integrated set of simulation models for predicting the acoustic and aerodynamic effects of porous surface materials at high Reynolds numbers. The corresponding CAA and CFD models use volume averaging of the porous surface and advanced representations of turbulence [11]. They are validated by dedicated geometry resolving Large Eddy Simulations [12] and aero-acoustic wind tunnel experiments.

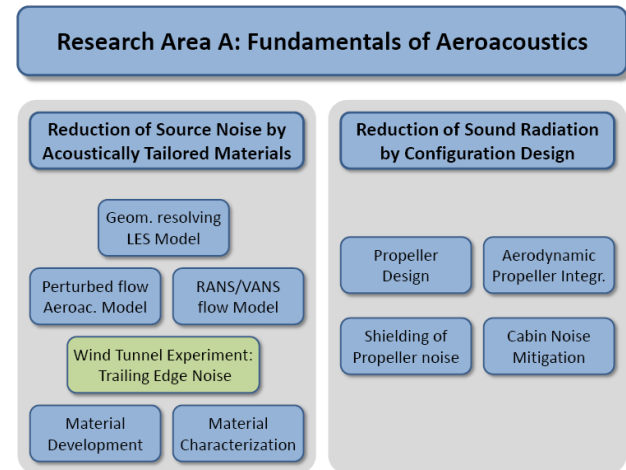

FIGURE 8. Schematics of research in aeroacoustics

The computational methods and experiments are used to provide fundamental knowledge on the physical mechanisms of noise source attenuation and noise absorption by porous surfaces. Computational results on the noise generation by vortex advection over an airfoil trailing edge are displayed in FIGURE 9. It could be demonstrated by careful set up of computations that noise mitigation offered by micro slits at the trailing edge is dominated by modification of the source near field through a perfusion flow between the two trailing edge sides. The effects of slits on turbulence can be neglected [13].

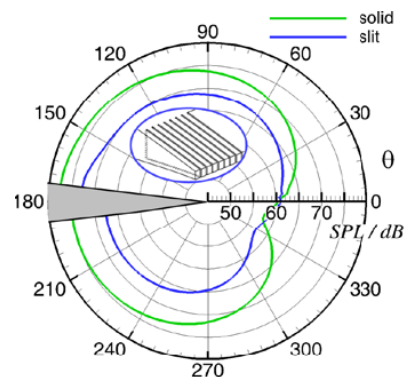

FIGURE 9. Computed measure of trailing edge noise emissions for solid and slit edges

The Research Area extends these results to a range of existing and new surface materials as displayed in FIGURE 10. These materials are superalloy membranes, sintered fibre felts, sintered powders, metallic foams, and perforated plates, covering a pore size range from 500 nm to 1 mm, and a porosity range from 15% to 95%. The

materials are thoroughly characterized with respect to their geometrical, mechanical, acoustics and flow-through properties. Special attention is on materials with non-isotropic porosities, as flow over a surface with isotropic porosity is a known source of noise by itself. FIGURE 11 presents microscopic views on two non-isotropic plate materials used. Commercially available Laser perforated plates (upper part) exhibit a slit width of around 100 μm . The Research Centre also develops new Ni-based superalloy membranes that exhibit smoothly distributed and directed pores in the 1-10 μm range [14],[15] as displayed in the lower part of FIGURE 11.

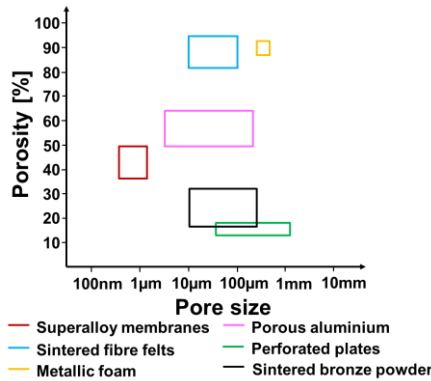

FIGURE 10. Overview of investigated surface materials

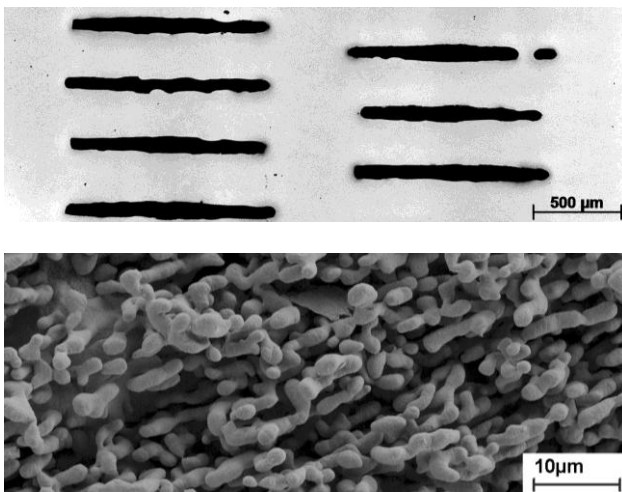

FIGURE 11. Surface Materials with nonisotropic permeability

The SFB 880 Reference Configuration employs propeller propulsion which is well suited for achieving high take-off thrust values along with low fuel burn in cruise. Acoustically, jet noise is practically eliminated by design. However, propeller sound radiation to the ground and the interactions of blade wakes with the wing call for mitigation. This is addressed by combined aerodynamic/acoustic design studies for propeller/airframe integration, maximizing noise shielding to the ground. Over-the-wing propeller arrangements have been therefore computationally analyzed. The aerodynamic results at take-off conditions display a positive interference effect on induced drag for over-the-wing propellers compared to classical tractors that would eventually improve aircraft climb angles by 2-3%. Acoustic shielding analysis with the DLR Fast

Multipole Method, on the other hand, shows a potential of 6dB propeller noise reduction for over-the-wing configurations [16]. Unfortunately, the propulsive efficiency of over-the-wing propellers at cruise conditions is significantly less than with tractors. This limits possible propeller positions as well as the cruise Mach number. It turns out that over-the-wing propellers cannot be used efficiently at Mach numbers beyond 0.6 [17].

To describe a reduction of a potentially increased vibration excitation of the aircraft structure by partial lining of shielding surfaces with porous material respective modeling and simulation of structure-borne sound are developed [18],[19].

3.2. Efficient High Lift

A drastic increase of flexibility in high-lift performance beyond the capabilities of classical mechanical multielement solutions can only be achieved by employing active flow control. Employing active flow control on commercial transport aircraft, however bears the risk that the systems used for power supply to the active high-lift devices and the mechanical power consumption itself introduce too high costs on the overall aircraft level and render active high-lift uncompetitive.

Research Area B therefore focuses on technologies that reduce the mechanical power needed for active lift and on means for drastic reductions of weight and cost of the associated systems. FIGURE 12 displays the schematic of the research efforts. Crucial is the choice of the aerodynamic approach for active flow control. It is well known that powerful control authority for flow turning is obtained by internal blowing over carefully designed blowing surfaces, hence making use of the Coanda effect [20].

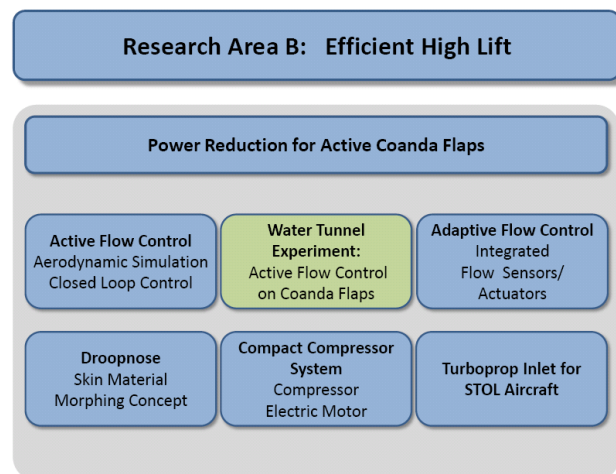

FIGURE 12. Schematics of research in efficient active high-lift

A suited measure of active-lift efficiency is the lift gain factor, LGF, that relates the lift increase to the momentum coefficient of blowing, c_{μ} :

$$\text{LGF} = (c_{L\text{max}} - c_{L\text{max,reference}}) / c_{\mu}$$

While preliminary research on the design of a suited wall jet thickness and the Coanda surface shape [21] had

achieved LGFs of around 83 for $c_L=4$ and 65 for $c_L=5$ (see blue data in FIGURE 13), the current interdisciplinary work of the SFB 880 explores four routes towards further improved exploitation of the blowing momentum:

- Reduce boundary layer losses upstream of the Coanda flap by a morphing droop nose.
- Use the benefits of boundary layer suction offered by installing distributed compressors along the wing span.
- Improve blowing efficiency by pulsed blowing.
- Explore the benefits offered by closed loop control of wall-jet blowing.

The first concept has already resulted in largely reduced blowing powers shown in Figure 13, as nose geometry deformations were used to alleviate the nose suction peak for reduced boundary layer losses [22]. The resulting airfoil shape is displayed in FIGURE 14. The droopnose also brings about a significantly larger angle of attack at maximum lift. This effect is strongly needed for aircraft flight during landing, see Chapter 3.3. The aerodynamic characteristics of the droopnose configuration will be verified using water tunnel tests in the near future.

Morphing droopnose geometries as shown in FIGURE 14 can be only accomplished by new structural technologies that combine highly deformable skins with suited attachments and new solutions for internal deformation mechanisms. A hybrid skin structure consisting of compliant elastomer combined with discrete fiber-reinforced stiff laminate bundles was developed and modeled [23] where the global bending strain is mainly conducted by the elastomer in the outer skin regions. Current manufactured configurations consisting of glass-fibre/epoxy and thermo-plastic polyurethane show an outstanding ratio of spanwise to chordwise bending stiffness of around 15. A two-stage optimization framework for the droopnose with large deformations was also developed. The first step optimizes the flexible skin and saves its stiffness parameters for the second step, which performs the topology optimization of interior kinematics with nonlinear structural behaviors [24].

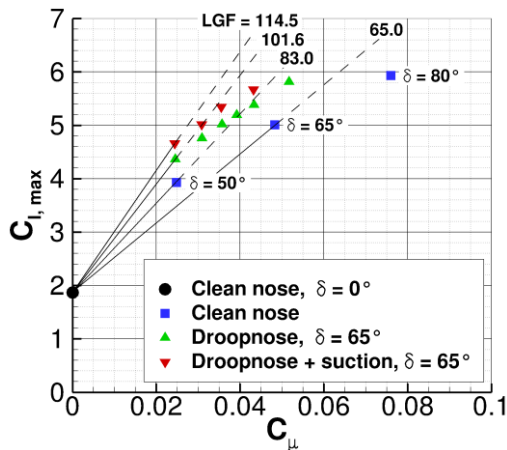
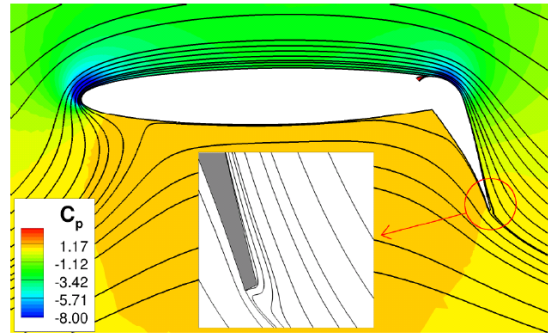
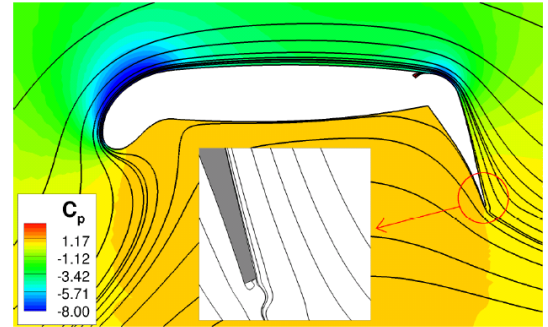

FIGURE 13. Lift gains versus blowing momentum obtained by droopnose and combined suction and blowing approaches (δ – deflection angle of flap)



a) Clean nose, $\alpha_{stall}= 3.0^\circ, c_L = 4.456$



b) Clean nose, $\alpha_{stall}= 12.3^\circ, c_L = 5.02$

FIGURE 14. Flow around active high-lift airfoil with morphing droop nose at $c_{\mu}=0.035$.

Using the benefits of boundary layer suction in combination with wall jet blowing relies on the concept that the pressurized air for blowing is generated by distributed compressors along the wing span. FIGURE 13 indicates that LGF improvements of around 15% may be expected from this approach. Mapping the compressor requirements in a Cordier diagram reveals that single-stage axial compressors are best suited. The requirements for low-weight efficient compressors with the needed range of operation call for compressor optimization. A two-stage optimization process is currently being developed and tested. During the preliminary design stage a large number of design variables are determined using simplified physical models and empirical correlations [25], whereas detailed design optimization is used to define profile and blade shapes.

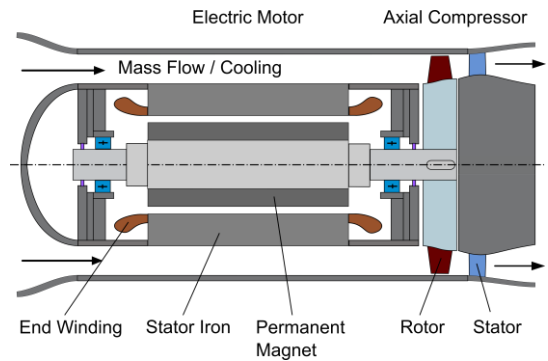

FIGURE 15. Motor integration in compressor concept

The challenge in the electric motor of the compressor lies in the high output power at high rotational speeds of up to 60,000 rpm. A synthesis of design constraints on rotor diameter, weight and efficiency has resulted in choosing a permanent magnet synchronous machine that is air-cooled using the air flow from the suction slot to the compressor [26], according to FIGURE 15. The strong interactions found between compressor, electric motor and power electronics motivate a joint design with an integrated optimization framework in future.

Pulsed blowing and closed-loop flow control make fast actuation devices and flow sensors necessary. Piezo ceramic multilayer actuators are therefore embedded in a metal substrate to allow slot control in flow experiments, as sketched in FIGURE 16. Specific design challenges result from the planned tests in a water tunnel. FEM analysis and load testing on a functional demonstrator indicate that the challenges from the high loads in water can be met. Also, suited coatings for waterproofing the actuators were developed. Flow sensing is performed with a combination of MEMS based pressure sensors to identify the unsteady flow turning and extremely thin hotfilms to measure the near-wall boundary layer flow. The actuation and sensing systems will be employed in future water tunnel tests for investigations of pulsed blowing and closed-loop control.

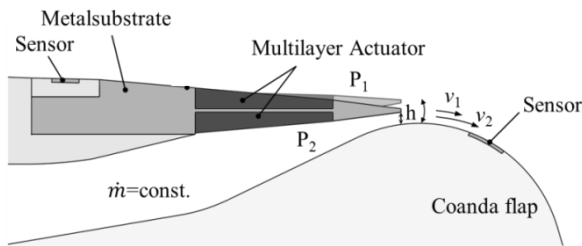

FIGURE 16. Concept sketch of integrated flow actuator and sensors for pulsed blowing and closed-loop control

The requirements to provide pressurized air in active high lift aircraft represent a significant challenge to the design of the core engine and its inlet. Preliminary design of a two-spool axial compressor turboprop addressed two variants: (i) Generation of pressurized air by bleed flow from the low pressure compressor and (ii) providing additional shaft power to an electric generator used to power distributed compressor systems along the wing span. These variants differ largely in turboprop engine size and the inlet mass flow. Detailed inlet designs and comparisons with reference inlets will identify the critical engine design trades involved here.

3.3. Flight Dynamics

Low-speed flight of cruise efficient commercial aircraft with short take-off and landing capabilities means flying at a much higher lift coefficient as commonly used in aircraft flight, and with the blowing rate as a new aircraft control parameter. This presents a number of research questions addressed by Research Area C. The elements of current research are seen in FIGURE 17. The wing stalling behavior is addressed by high-fidelity simulations of the full Reference Configuration [27]. Initial results for Coanda flaps without leading edge device as displayed in FIGURE 18 reveal stall at low angles of attack, $\alpha=3^\circ$, which would

exclude a useful landing operation. Wings with large flow turning by active means generate a large negative pitching moment that is important for trim. Besides static effects the active lift system also contributes unknown behaviors of the dynamic derivatives relevant for longitudinal and lateral aircraft motions. Moment coefficients and derivatives must be known for unsymmetrical engine failure cases, and they are obtained by a number of numerical flow computations. The aerodynamic data is used to define the flight mechanics model. This model is used for static and dynamic flight simulations which take into account the atmospheric gust flow environment close to airports.

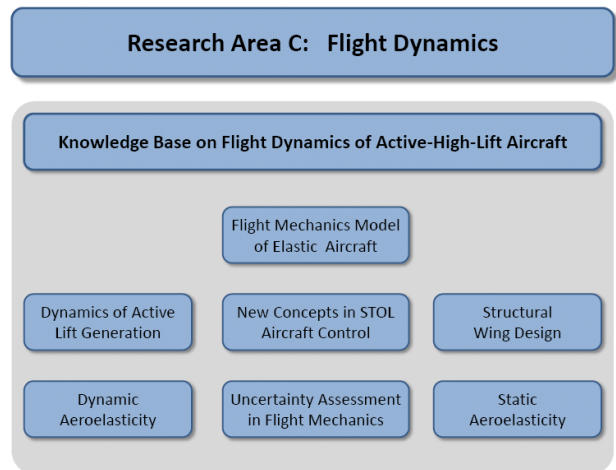

FIGURE 17. Schematics of research in flight dynamics

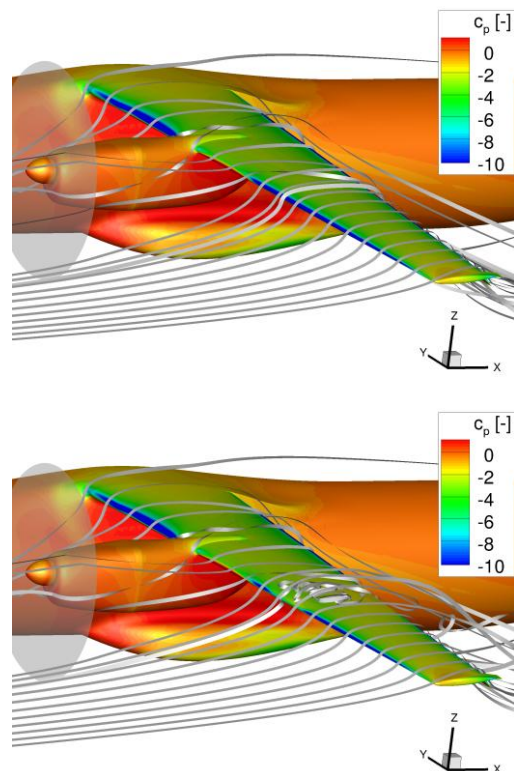

FIGURE 18. RANS simulation of wing stall of complete Reference Configuration with Coanda flaps at $\delta=65^\circ$ and $c_{\mu}=0.033$ on wing: $\alpha=2^\circ$ below stall (upper part) and $\alpha=3^\circ$ beyond stall (lower part)

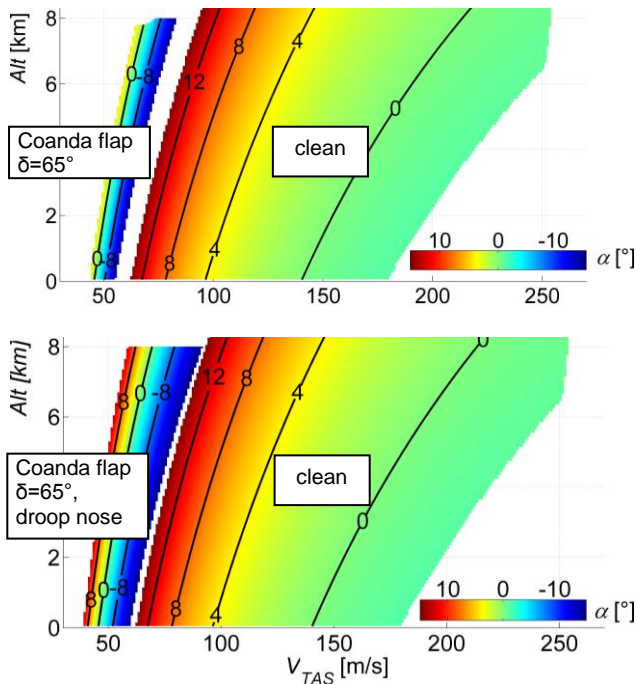

FIGURE 19. Trimmed flight envelopes for Reference Configuration with and without high-lift setting: Fixed nose (upper part) and morphing droopnose (lower part)

The model has delivered the trim envelopes of the Reference Configuration shown in FIGURE 19 [28]. While the configuration without leading edge device has a much too small incidence range of flight, the Reference Configuration with droopnose as of FIGURE 14 exhibits a larger trim envelope that would allow usual landing approaches. Future flight simulations will address flight control behaviors at the low dynamical pressure of the Reference Configuration and the specific stability problem of flying far on the backside of the power curve.

There exists little published knowledge about the aeroelastic phenomena of wings with active high lift. These are elastic behaviors of the slots used for flow control, static torsion divergence, control reversals, and low speed flutter. Therefore work is performed to investigate elastic effects by employing structural and aerodynamic models of varying fidelity. These models are based on a fully stressed wing structure along with detailed packaging of the needed systems [29]. This model is used for deformation analysis of slots and the global wing [30]. Also reduced models for flutter analysis are derived by using modal analysis of the detailed model. The flutter analysis employs wing bending and torsion degrees of freedom [31]. An unsteady aerodynamic model that takes the non-linear lifting behavior of Coanda flaps into account was defined using a data base of Navier-Stokes simulations. First results indicate that low-speed bending flutter may exist because of vanishing aerodynamic damping observed close to maximum wing lift, and depending of the blowing momentum. The reduced aeroelastic flutter model is also integrated with the flight mechanical model, to study interactions of flight mechanics and aeroelasticity.

The flight simulations of the Reference Configuration with active high-lift exhibit many uncertainties that have their origin in the computational approaches for aerodynamics and structures, in the reduction process for flutter compu-

tations, and further in assuming a model of the atmosphere. As the Reference Configuration is rather far away from the range of existing knowledge it is felt that a well-founded analysis of uncertainty on the flight dynamics is a useful area of research investigations. While classical Monte-Carlo simulations can be used to address the effects of uncertain input data, this is generally not practical if many parameters are uncertain. The Research Centre develops therefore a range of modern stochastic methods. The stochastic collocation method does not need any changes of the original flight mechanical computation code (nonintrusive uncertainty approach). This method was shown around two orders of magnitude more efficient than direct Monte Carlo integration [32]. It will be used in future studies to assess robustness in flight mechanical behaviors.

4. CONCLUSIONS

The Collaborative Research Centre SFB 880 combines the competencies of Technische Universität Braunschweig, Universität Hannover and the German Aerospace Center, DLR, for fundamental and applied research in high-lift of future commercial aircraft. Based on a thorough analysis of long term requirements for sustained growth in aviation the Centre focused its research on the fundamentals in aeroacoustics and on efficient and viable approaches towards active high-lift. The research activities combine the disciplines of aerodynamics, aeroacoustics, materials, structures, adaptronics, turbomachinery and flight mechanics. The Centre is now in its third year of research, and the results obtained so far are significant and promising. Future work will aim at combining more of the disciplinary models and technologies in order to cope with the multidisciplinary aspects of the design problems and to exploit synergies as well. The Centre welcomes opportunities for new cooperations with other researchers in the field.

ACKNOWLEDGEMENT

The funding of the Coordinated Research Centre SFB 880 by the German Research Foundation, DFG, is thankfully acknowledged.

REFERENCES

- [1] Flightpath2050 – Europe's Vision for Aviation, Report on the High Level Group on Aviation Research, ISBN 978-92-79-19724-6, 2011, www.acare4europe.org.
- [2] Henke, R., Lammering, T., Anton, E.: Impact of an Innovative Quiet Regional Aircraft on the Air Transportation System. *Journal of Aircraft*, Vol. 47, No. 3, 2010, pp. 875-886.
- [3] Werner-Westphal, C., Heinze, W., and Horst, P.: Multidisciplinary Integrated Preliminary Design Applied to Unconventional Aircraft Configurations. *Journal of Aircraft*, Vol. 45, No. 2, 2008, pp. 581-590.
- [4] Werner-Spatz, C., Heinze, W., Horst, P., Radespiel, R.: Multidisciplinary Conceptual Design for Aircraft with Circulation Control High-Lift Systems. *CEAS Aeronautical Journal*, Vol. 3, pp. 145-164, 2012.
- [5] Koeppen, C.: Method for Model-Based Estimations of System Mass in Aircraft Pre-Design. Proceedings of the 66th Annual Conference of the Society of Allied Weight Engineers, SAWE Paper No. 3428, Los Angeles, CA, 2007.

- [6] Mattingly, J. D., Heiser, W. H., and Daley, D.H., Aircraft Engine Design. Appendix H Turboprop Engine, AIAA, New York, 1987, pp. 507-531.
- [7] Baum, J. A., Dumais, P. J., Mayo, M. G., Metzger, F. B., Shenkman, A. M., and Walker, G. G.: Prop-Fan Data Support Study, Technical Report. NASA CR-152141, Moffett Field, CA, Feb. 1978.
- [8] Delfs, J., Faßmann, B., Lippitz, N., Lummer, M., Mößner, M., Müller, L., Rurkowska, K., Uphoff, S.: SFB 880 – Fundamentals of Aeroacoustics. Proceedings Deutscher Luft- und Raumfahrtkongress, 10.-12. September 2013, Stuttgart, Germany, 2013.
- [9] Seume, J., Teichel, S., Burnazzi, M., Schwerter, M., Behr, C., Rudenko, A., Schmitz, A., Dörbaum, M. Atalayer, Ç.: SFB 880 – Efficient High Lift. Proceedings Deutscher Luft- und Raumfahrtkongress, 10.-12. September 2013, Stuttgart, Germany, 2013.
- [10] Horst, P., Keller, D., Diekmann, J., Krukow, I., Sommerwerk, K.: SFB 880 – Flight Dynamics. Proceedings Deutscher Luft- und Raumfahrtkongress, 10.-12. September 2013, Stuttgart, Germany, 2013.
- [11] Mößner, M., Radespiel, R.: Numerical Simulations of Turbulent Flows over Porous Media. AIAA-2013-2963, 2013.
- [12] Uphoff, S., Krafczyk, M.: Numerical Simulation of Sound Absorption in an Impedance Tube and Turbulent Flow Around a Flat Plate. In: Radespiel, R., Semaan, R. (Eds.): SFB 880 – Fundamentals of high-lift for future commercial aircraft. ISBN 978-3-928628-63-1, 2013, pp. 40-51.
- [13] Faßmann, B., Delfs, J., Ewert, R., Dierke, J.: Reduction of Emitted Sound by Application of Porous Trailing Edges. In: Radespiel, R., Semaan, R. (Eds.): SFB 880 – Fundamentals of high-lift for future commercial aircraft. ISBN 978-3-928628-63-1, 2013, pp. 1-11.
- [14] Hinze, B., Rösler, J., Schmitz, F.: Production of nanoporous superalloy membranes by load-free coarsening of γ' – precipitates. Acta Materialia, Vol. 59, 2011, pp. 3049-3060.
- [15] Rösler, J., Krause, W., Hinze, B.: A Concept for the Control of Pore Size in Superalloy Membranes, Metals, Vol. 4, 2014, pp.1-7.
- [16] Müller, L., Lummer, M., Kozulovic, D., Delfs, J., Hepperle, M.: Aerodynamic and Acoustic Assessment of a High-Lift Channel Wing Configuration. In: Radespiel, R., Semaan, R. (Eds.): SFB 880 – Fundamentals of high-lift for future commercial aircraft. ISBN 978-3-928628-63-1, 2013, pp. 12-28.
- [17] Müller, L., Kozulovic, D., Radespiel, R.: Aerodynamic Performance of an Over-the-wing Propeller Configuration at Increasing Mach Number. Proceedings Deutscher Luft- und Raumfahrtkongress, 10.-12. September 2013, Stuttgart, Germany, 2013.
- [18] Rurkowskaja, K., Langer, S., Beck, S.C.: Flow Induced Sound in Poroelastic Materials. In: Radespiel, R., Semaan, R. (Eds.): SFB 880 – Fundamentals of high-lift for future commercial aircraft. ISBN 978-3-928628-63-1, 2013, pp. 52-62.
- [19] Zahid, M., Beck, S.C., Langer, S.: Modeling of flow-induced sound in poroelastic materials, BIOT-5, 5th Biot Conference on Poromechanics, Wien, 2013.
- [20] Yaros, S. F., et al.: Synergistic Airframe-Propulsion Interactions and Integrations, NASA/TM-1998-207644, 1998.
- [21] Jensch, C., Pfingsten, K. C., Radespiel, R., Schuermann, M., Haupt, M., and Baus, S.: Design Aspects of a Gapless High-Lift System with Active Blowing, Deutscher Luft- und Raumfahrtkongress, 8.-10. September 2009, Aachen, Germany, 2009.
- [22] Burnazzi, M., and Radespiel, R.: Design of a Droopnose Configuration for a Coanda Active Flap Application, AIAA 2013-487, 2013.
- [23] Schmitz, A., Horst, P.: Numerical modeling of the change in stiffness properties of cross-ply laminates subjected to large bending curvatures. Key Engineering Materials 2014; Vol. 577-578, pp. 173-176.
- [24] Rudenko, A., Monner, H.P., Rose, M.: A process chain for structural optimization of a smart droop nose for an active blown high lift system. AIAA 2014-1414, 2014.
- [25] Teichel, S., Verstraete, T., Seume, J.: Optimized preliminary design of compact axial compressors: A comparison of two design tools. AIAA-2013-2652, 2013.
- [26] Dörbaum, M., Juris, P., Stübiger, C., Ponick, B.: Design of High Speed Motor with a High Power Range for Use in Future Aircraft, PCIM Europe, Nürnberg, 2013.
- [27] Keller, D.: Numerical Investigation of Engine Effects on the Stability and Controllability of a Transport Aircraft with Circulation Control. AIAA-2013-3031.
- [28] Diekmann, J.H.: Trim Analysis of Nonlinear Flight Dynamics for a Civil Aircraft with Active High Lift. Proceedings Deutscher Luft- und Raumfahrtkongress, 10.-12. September 2013, Stuttgart, Germany, 2013.
- [29] Sommerwerk, K. and Haupt, M.: "Design analysis and sizing of a circulation controlled CFRP wing with Coanda flaps via CFD-CSM coupling", CEAS Aeronautical Journal, Vol. 5, No.1, 2014, pp. 95-108.
- [30] Sommerwerk, K., Haupt, M. and Horst, P.: Aeroelastic Performance Assessment of a Wing with Coanda Effect Circulation Control via Fluid-Structure Interaction. AIAA-2013-2791, 2013.
- [31] Krukow, I., Dinkler, D.: A reduced-order model for aeroelastic studies on airfoils with active high-lift devices. Proceedings International Forum on Aeroelasticity & Structural Dynamics, 24-26 June 2013, Bristol, UK, 2013.
- [32] Rosic, B.V., Diekmann, J.H.: Non-Intrusive Methods for the Uncertainty Quantification of the basic Aircraft Model (BACM). In: Radespiel, R., Semaan, R. (Eds.): SFB 880 – Fundamentals of high-lift for future commercial aircraft. ISBN 978-3-928628-63-1, 2013, pp. 204-216.